

9452/9462

Hot Water - Gas Fired Burner Modules

Operator's Manual

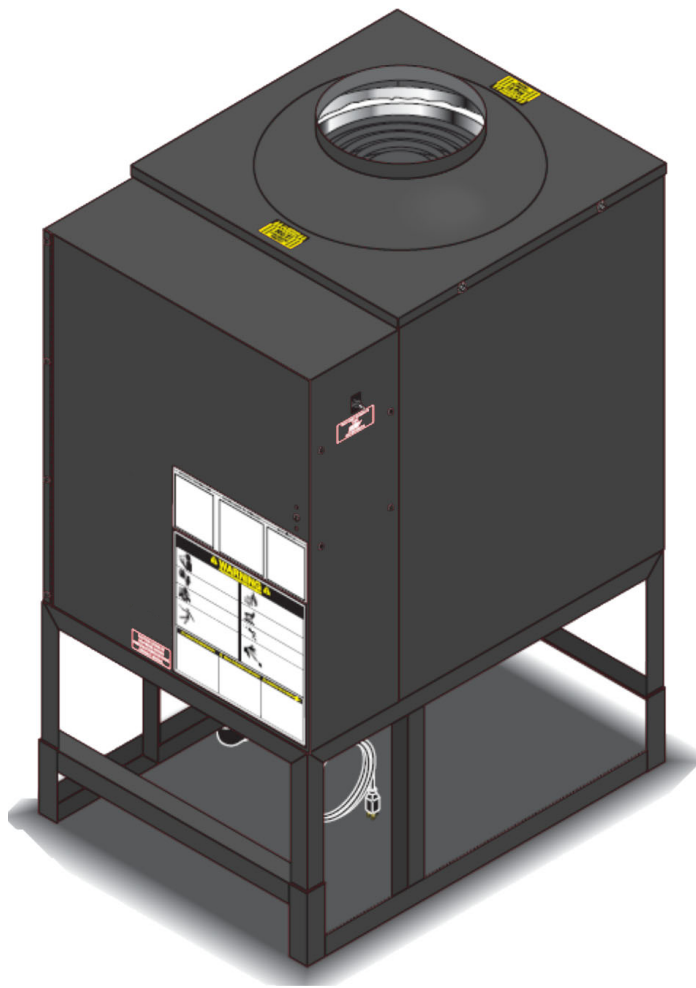

MODELS:

9452
1.103-906.0

9462
1.103-908.0

For the Dealer nearest you,
consult our web page at
www.kaercher/us/.com



8.914-365.0- AB 11/29/22

Machine Data Label

Model: _____

Date of Purchase: _____

Serial Number: _____

Dealer: _____

Address: _____

Phone Number: _____

Sales Representative: _____

Machine Data Label2
Table of Contents3
How To Use This Manual4

Safety

Introduction & Safety Information5
IMPORTANT SAFETY INFORMATION5

Operations

Technical Specification8
Component Identification9
Installation10
Checklist Prior To Operation14
Operation Instructions15
Detergents And General Cleaning Techniques . . .16
Shutting Down And
 Clean-Up17
Basic Facts18

Maintenance

Preventative Maintenance20
Winterizing Procedure20
Heating Coils20
Gas Valve Regulator Adjustment20
Pressure Relief Valve21
Gas Pressure Requirements21
Burner Features21
Oil Change Record23
Troubleshooting24

How To Use This Manual

This manual contains the following sections:

- How to Use This Manual
- Safety
- Operations
- Maintenance

The HOW TO USE THIS MANUAL section will tell you how to find important information for ordering correct repair parts.

Parts may be ordered from authorized dealers. When placing an order for parts, the machine model and machine serial number are important. Refer to the MACHINE DATA box which is filled out during the installation of your machine. The MACHINE DATA box is located on the inside of the front cover of this manual.

Model: _____
Date of Purchase: _____
Serial Number: _____
Dealer: _____
Address: _____
Phone Number: _____
Sales Representative: _____

The model and serial number of your machine is located on the back of the machine.

The SAFETY section contains important information regarding hazardous or unsafe practices of the machine. Levels of hazards are identified that could result in product damage, personal injury, or severe injury resulting in death.

The OPERATIONS section is to familiarize the operator with the operation and function of the machine.

The MAINTENANCE section contains preventive maintenance to keep the machine and its components in good working condition. They are listed in this general order:

- Preventative Maintenance
- Winterizing Procedure
- Heating Coils
- Gas Valve Regulator Adjustment
- Pressure Relief Valve
- Gas Pressure Requirements
- Burner Features
- Oil Change Record
- Troubleshooting

The PARTS LIST section contains assembled parts illustrations and corresponding parts list. The parts lists include a number of columns of information:

- **REF** – column refers to the reference number on the parts illustration.
- **PART NO.** – column lists the part number for the part.
- **QTY** – column lists the quantity of the part used in that area of the machine.
- **DESCRIPTION** – column is a brief description of the part.
- **NOTES** – column for information not noted by the other columns.

NOTE: If a service or option kit is installed on your machine, be sure to keep the KIT INSTRUCTIONS which came with the kit. It contains replacement parts numbers needed for ordering future parts.

NOTE: The manual part number is located on the lower right corner of the front cover.

Introduction & Safety Information

Thank you for purchasing a Heating Module.

This manual covers the operation and maintenance of the 9452, 9462 heating modules. All information in this manual is based on the latest product information available at the time of printing.

We reserve the right to make changes at any time without incurring any obligation.

When ordering parts, please specify model and serial number.

Owner/User Responsibility:

The owner and/or user must have an understanding of the manufacturer's operating instructions and warnings before using this water heater. Warning information should be emphasized and understood. If the operator is not fluent in English, the manufacturer's instructions and warnings shall be read to and discussed with the operator in the operator's native language by the purchaser/owner, making sure that the operator comprehends its contents.

SAVE THESE INSTRUCTIONS

This manual should be considered a permanent part of the machine and should remain with it if machine is resold.

When ordering parts, please specify model and serial number. Use only identical replacement parts.

This machine is to be used only by trained operators.

IMPORTANT SAFETY INFORMATION

WARNING: When using this machine, basic precautions should always be followed, including the following:

AVERTISSEMENT: En utilisant cette machine, des précautions de base devraient toujours être observées, y compris ce qui suit :



WARNING: To reduce the risk of injury, read operating instructions carefully before using.

AVERTISSEMENT: Pour réduire le risque de blessures, lire attentivement les instructions de fonctionnement avant l'utilisation.

1. Read the owner's manual thoroughly. Failure to follow instructions could cause malfunction of the machine and result in death, serious bodily injury and/or property damage.

Safety

- All installations must comply with local codes. Contact your electrician, plumber, utility company or the selling dealer for specific details.



WARNING: Flammable liquids can create fumes which can ignite causing property damage or severe injury.

AVERTISSEMENT: Des liquides inflammables peuvent produire des vapeurs qui peuvent s'enflammer, causant ainsi des dommages à la propriété ou des

blessures graves

- Risk of explosion - do not spray flammable liquids or operate in an explosive location. Operate only where open flame or torch is permitted.
- Do not attach a gasoline operated pressure washer to this machine because gas vapors will ignite.



DANGER: Keep water spray away from electrical wiring or fatal electric shock may result. Read warning tag on electrical cord.

DANGER: Garder le jet d'eau à l'écart de tout câblage électrique ou des chocs électriques mortels pourraient survenir.

5. To protect the operator from possible electrical shock, the machine must be electrically grounded. It is the responsibility of the owner to connect this machine to a UL grounded receptacle of proper voltage and amperage ratings. Do not spray water on or near electrical components. Do not touch machine with wet hands or while standing in water. Always disconnect power before servicing.



WARNING: Spray gun kicks back. Hold with both hands.

AVERTISSEMENT: Le pistolet pulvérisateur peut présenter un risque de retour; le tenir avec les deux mains.

6. Grip cleaning wand (not included) securely with both hands before starting the cleaner. Failure to do this could result in injury from a whipping wand.



WARNING: High pressure stream of fluid from the pressure washer attached to this equipment can produce a high pressure stream of fluid that can pierce skin and its underlying tissues, leading to serious injury and possible amputation.

AVERTISSEMENT: Le jet de liquide haute pression de la laveuse à pression attaché à cet équipement peut percer la peau et ses tissus sous-jacents, causant ainsi des blessures graves et possiblement une amputation.

- High pressure developed by this machine can cause personal injury or equipment damage. Use caution when operating. Do not direct discharge stream at anyone or at any part of the body, or severe injury or death may result. This machine is to be used only by qualified operators.

- Never make adjustments on machine while in operation.



WARNING: High pressure spray can cause paint chips or other particles to become airborne and fly at high speeds. To avoid personal injury, eye, hand and foot safety devices must be worn.

AVERTISSEMENT: Un jet haute pression peut écailler la peinture ou provoquer l'émission d'autres particules dans l'air et leur projection à hautes vitesses. Pour éviter les lésions corporelles, une protection des yeux, du visage, des mains et des pieds doit être portée lors de l'utilisation de cet équipement.

- Wear properly rated eye protection such as safety goggles or face shield while spraying. (Safety glasses do not provide full protection.)



DANGER: Risk of asphyxiation. Use this product only in a well ventilated area.

DANGER: Risque d'asphyxie. Utiliser ce produit uniquement dans un endroit bien ventilé.

- When the machine is working, do not cover or place in a closed space where ventilation is insufficient.



WARNING: Protect machine from freezing.

AVERTISSEMENT: Protéger la machine contre le gel.

- Be certain all quick coupler fittings are secured before using pressure washer.
- Do not allow acids, caustic, or abrasive fluids to pass through the pump.
- Inlet water must be cold and clean fresh water.
- Do not allow CHILDREN to operate this equipment at any time.
- The best insurance against an accident is precaution, and knowledge of the machine.
- Do not operate this product when fatigued or under the influence of alcohol or drugs. Keep operating area clear of all persons.
- Never expose a spark or flame where there may be unburned gas present.
- Never attempt to light pilot unless pilot manual valve has been shut off for 5 minutes.



WARNING: Use only vapor fuel.

AVERTISSEMENT: Utiliser des vapeurs de carburant seulement.

- A conversion kit, as supplied by the manufacturer, shall be used to convert natural gas to propane.
- This equipment is designed to run on vapor fuel. Do not use liquid fuel. Have a qualified serviceman install and service your equipment.
- L.P. gases are heavier than air and will spill out on the floor. Therefore always provide adequate space and ventilation around these machines.
- We will not be liable for any changes made to our standard machines, or any components not purchased from us.
- Do not overreach or stand on unstable support. Keep good footing and balance at all times.

- When making repairs disconnect from electrical source and shut off gas valve.
- Before disconnecting discharge hose from water outlet, turn burner off and open spray gun to allow water to cool below 100° before stopping the machine. Then open the spray gun to relieve pressure. Failure to properly cool down or maintain the heating coil may result in a steam explosion.



- Extinguish any open flame and test all joints with a soap solution. If odor persists, call your gas supplier immediately.
- This machine must be attended during operation.
- Consult local codes and ordinances for proper stacking type and size.
- A draft hood shall be installed on this machine and vented to the outside of the building.
- Inspect pressure safety relief/rupture disk for obstruction every three (3) months.



WARNING: If connection is made to potable water supply, a back flow device must be provided.

AVERTISSEMENT: Si une connexion est établie avec un approvisionnement en eau potable, un dispositif de protection contre le retour d'eau doit être fourni.



WARNING: Do not spray machine or any people, animals or electrical parts.

AVERTISSEMENT: Ne pas vaporiser sur la machine ou les gens, les animaux ou les pièces électriques.



Follow the maintenance instructions specified in the manual.

Operations

Technical Specification

Model #	Maximum Inlet	Machine Voltage	Total Machine Amperage	Burner Type	Exhaust Stack Size	Machine Weight	Shipping Weight	Machine Dimensions
9452	3200 PSI	120V	1 Amps	Natural Gas, LP (Optional) 540,000 BTU/Hr Max	10"	470 Lbs	500 Lbs	L 32.5" X W 25" X H 50.5"
9462	3200 PSI	120V	1 Amps	Natural Gas, LP (Optional) 920,000 BTU/Hr Max	12"	880 Lbs	935 Lbs	L 40.5" X W 32" X H 65"

Component Identification

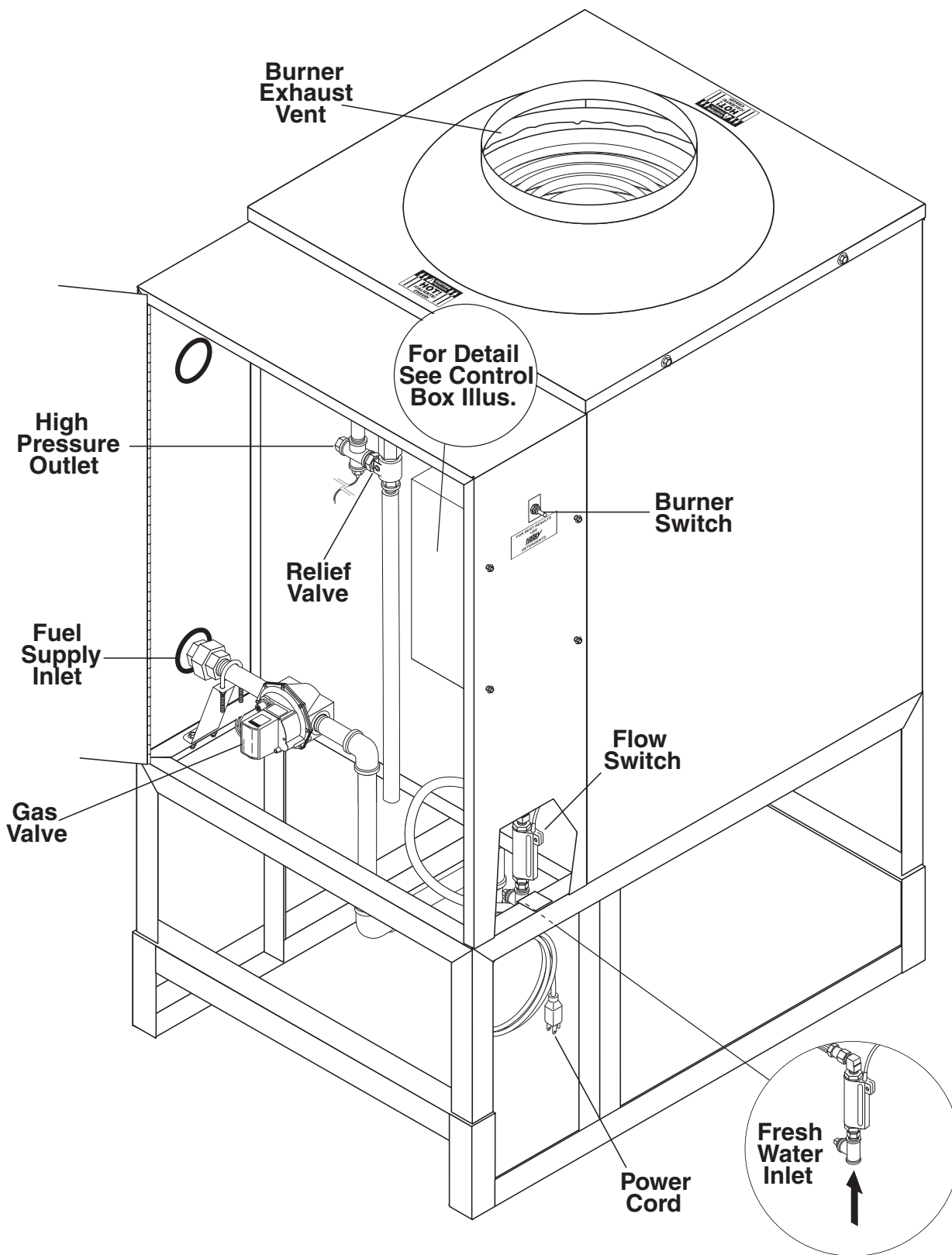

Operations

Installation

Place machine in a convenient location providing ample support, drainage and room for maintenance.

Location

This machine is certified for indoor installation. Its location should protect the machine from damaging environmental conditions, such as wind, rain and freezing.

1. The machine should be run on a level surface where it is not readily influenced by outside sources such as strong winds, freezing temperatures, rain, etc. The machine should be located considering accessibility of the components and the refilling of detergents, adjustments and maintenance. Normal precautions should be taken by operator of machine to prevent excess moisture from reaching power machine or electrical controls.
2. It is recommended that a partition be made between wash area and machine to prevent direct spray from spray gun from coming in contact with machine. Excess moisture reaching pressure washer or electrical controls will reduce life of machine and may cause electrical shorts.
3. During installation of machine, beware of poorly ventilated locations or areas where exhaust fans may cause an insufficient supply of oxygen. Sufficient combustion can only be obtained when a sufficient supply of oxygen is available for the amount of fuel being burned. If it is necessary to install a machine in a poorly ventilated area, outside fresh air may have to be piped to burner and a fan installed to bring air into area.
4. Do not locate near any combustible material. Keep all flammable material at least 20 feet away.

Allow enough space for servicing the machine.

Local code will require certain distances from floor and walls. (Two feet away should be adequate.)

AVOID SMALL LOCATIONS OR AREAS NEAR EXHAUST FANS.

Gas Codes:

Confer with local gas company and with proper municipal officials regarding any specific code or regulations governing the installation. The installation must conform to local codes.

Electrical

The machine, when installed, must be electrically grounded in accordance with local codes. Check for proper power supply using a volt meter; check the serial plate for the correct requirements.

Gas Piping

All piping must comply with local codes and ordinances of the National Fuel Gas Code. A sediment trap or drip leg must be installed in the supply line to the burner.

A union shall be installed in the gas line adjacent to and upstream from the control manifold and downstream from the manual main shut-off valve.

A 1/8" N.P.T. plugged tapping accessible for test gauge connection shall be installed immediately upstream of the gas supply connection for the purpose of determining the gas supply pressure to the burner, and to prevent damage to gas valve.

If a manual gas shut off valve is not in the gas supply line within six feet of the machine and in an accessible location, one shall be installed.

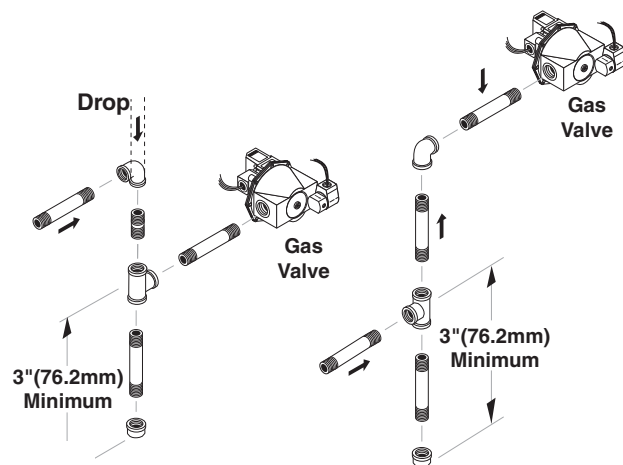

Sediment trap (drip leg) must be installed in the supply line.

A manual shut-off valve shall be installed in the gas supply line external to the appliance. The gas line should be a separate supply direct from the meter to the burner. It is recommended that new pipe be used and located so that a minimum amount of work will be required in future servicing. The piping should be installed to be durable, substantial and gas tight. It should be clear and free from cutting burrs and defects in structure of threading. Cast iron fittings or aluminum tubing should not be used for the main gas circuit. Joint compounds (pipe dope) should be used sparingly on male threads only and be approved for all gases.

Propane Gas

The following pipe and stack sizes are just recommendations. Always consult a local plumber and venting contractor for local codes and regulations during installation. The following tables are maximum capacity of final stage pipe in thousands of BTU/Hr. of commercial propane:

From first stage regulator (at tank) to second stage regulator.

The chart below is based on incoming gas pressure of 10 PSI and a pressure drop of 1 PSI. Numbers are for straight schedule 40 pipe; fittings further reduce capacity.

Propane		
Length of Pipe (ft.)	Iron Pipe Size	
	1/2"	3/4"
10	3339	6982
20	2295	4799
30	1843	3854
40	1577	3298
50	1398	2923
60	1267	2649
70	1165	2437
80	1084	2267
90	1017	2127
100	961	2009
150	772	1613
200	660	1381
250	585	1224
300	530	1109
350	488	1020
400	454	949
450	426	890
500	402	84

From second stage regulator to machine.

The following chart is based on incoming gas pressure of 11 w.c.i. and a drop of 5 w.c.i. Numbers are for straight schedule 40 pipe; fittings further reduce capacity.

Propane			
Length of pipe (ft.)	Iron Pipe Size		
	1/2"	3/4"	1"
10	291	608	1146
20	200	418	788
30	161	336	632
40	137	287	541
50	122	255	480
60	110	231	435
70	102	212	400
80	94	198	372
90	87	185	349
100	84	175	33

The chart below is based on gas pressure in the range 0-.5 PSI, specific gravity of .6, and a pressure loss of .5 w.c.i. Numbers are for straight schedule 40 pipe; fittings further reduce capacity.

Natural Gas					
Length of Pipe (ft.)	Iron Pipe Size				
	3/4"	1"	1 -1/4"	1-1/2"	2"
10	360	680	1400	2100	3950
20	250	465	950	1460	2750
30	200	375	770	1180	2200
40	170	320	660	990	1900
50	151	285	580	900	1680
60	138	260	530	810	1520
70	125	240	490	750	1400
80	118	220	460	690	1300
90	110	205	430	650	1220
100	103	195	400	620	1150
150	84	160	325	500	950
200	72	135	280	430	80

Venting

If the machine is used indoors, regulations or ventilation concerns may call for a chimney or furnace pipe. When venting, if the heating module is to be in an enclosed area with a chimney on it, be sure the chimney is the same size as the stack on the module. Poor draft will cause the machine to soot and not operate efficiently. When installing, keep in mind that the machine should be positioned in such a manner that the stack will be as straight as possible and protrude through the roof of the building at a proper location and at sufficient height to eliminate downdraft. The chimney shall be installed with a down draft diverter. Natural and LP gas series pressure washers that incorporate a natural draft burner assembly designed to heat water that comes from the pressure washer pump require a draft diverter and vent pipe for exhausting to the outside. This operator's manual indicates this machine is to be vented through the ceiling using straight pipe or 45° elbows. It also discourages the use of any 90° venting elbows which restrict air flow through the burner causing poor burner conditions. If this machine is going to be installed to a 90° or extended exhaust vent run length which may restrict air flow it is recommended that a contractor install a power vent. When a contractor has found it impossible to vent through the ceiling then power venting can be calculated to help eliminate exhaust restriction on this natural draft machine. This draft inducer (power vent) must be installed by a licensed contractor who can calculate size, operation connections and associated dampeners. We are not a licensed contractor and as such we are unable to make recommendations for suitable make and model of power vents. It is important that the licensed contractor consult local building codes. We can only make recommendations and the selection of the venting must take into account the type of roof or wall material it contacts which could change the vent requirement for compliance with local building codes

Draft Diverter

The draft diverter shall be installed at least three (3) feet above the heating coil. The diverter serves to sever the chimney effect created in all sections of furnace pipe positioned below to enhance the draft through the burner. It also helps prevent freezing of the coil due to wind chill factors. (Optional)

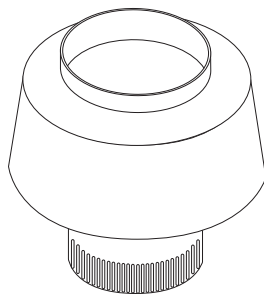

When a room is of unusually tight construction and has a kitchen and/or bathroom ventilating fan, which may be used for exhausting air to outdoors - or has a vented fireplace - it is recommended that combustion air be supplied to the enclosed room through intakes extending to the outside of the building and terminating in down turned fittings, suitably arranged to prevent obstruction from snow or rain, and including a protecting screen not smaller than 1/4 inch mesh.

Illustration showing air openings necessary to supply air for combustion when installed in an enclosed room.

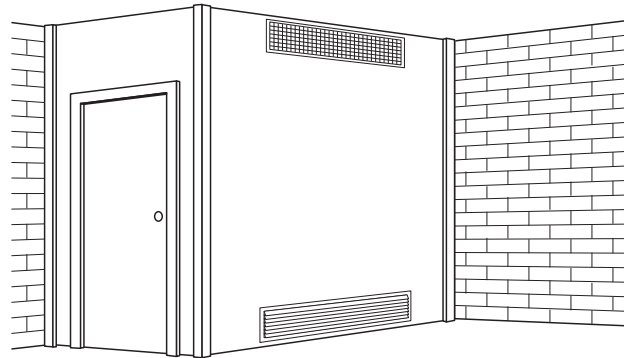

Ventilating air openings - 1/2 square inch for each 1000 BTU per hour input for make-up air from outside the building.

Water Source

The heating module was designed to accept a cold water electric pressure washer. The water source for the attached pressure washer should be supplied by a 5/8" I.D. garden hose with a city water pressure of not less than 30 psi. If the water supply is inadequate, or if the garden hose is kinked, the machine will run very rough and the burner will not fire.

Inspection and Testing Gas Piping

The building structure should not be weakened by installing the gas piping. The piping should not be supported by other piping, but should be firmly supported with gas hooks, straps, bands or hangers. Butt or lap welded pipe should not be run through or in an air duct or clothes chute.

Before turning gas on, close all openings from which gas can escape. Check system for leaks immediately after turning gas on. This can be done by watching the 1/2 cubic foot test dial and allowing 5 minutes to show any movement, or by soaping each pipe connection and watching for bubbles. If a leak is found, make the necessary repairs and repeat the above test.

Defective pipes or fittings should be replaced and not repaired. Never use a flame or fire in any form to locate gas leaks; use a soap solution.

After the piping and meter have been checked completely, purge the system of air. **DO NOT** bleed the air inside an enclosed room.

The appliance and its individual shut-off valve must be disconnected from the gas supply piping system during the pressure testing of that system at test pressure in excess of 1/2 psig or damage to the gas valve will occur.

Gas Pressure

The ideal incoming gas pressure is 11 w.c." (minimum 6 w.c.", maximum 14 w.c." or 1/2 psig). The correct operating manifold pressure for natural gas is 3.5 w.c." The operating manifold pressure for propane gas is 11 w.c." By adjusting the gas valve pressure regulator between 3 and 4 w.c.i. for the NG and 6 and 11 w.c." for the LPG, a side range can be achieved.

If the desired input rating cannot be obtained within the above manifold pressure adjusting range, the next size larger or smaller burner orifice should be used.

The gas pressure coming out of the regulator and going to the burner ring has been factory set for elevations of 0 to 2000 ft. Altitudes greater than 2000 ft will require adjustments to the gas manifold pressures. Consult your local service dealer/dealer for high altitude adjustments. In Canada, certification for installation at altitudes over 4500 feet above sea level is the jurisdiction of local authorities. You should not readjust the burner ring gas pressure. If you replace your gas valve, you will need to adjust the new valve. Refer to your machine's **specification plate** for the correct pressure setting. Follow the installation and adjustment instructions provided with your replacement valve.

NOTE: Air for combustion and ventilation along with exhaust flue sizing must conform to methods outlined in current American Standard (ANSI-Z223.1) National Fuel Gas Code or National Standard of Canada CSA-149.1 and CSA-149.2 "Installation Code for Gas Burning Appliances".

Warning & Check List



1. Installation or servicing of gas appliances and controls must only be performed by qualified personnel. After installation or servicing, test manual valve, operating valves, pressure regulation, and automatic shut-off valve for proper operation.
2. Install in a suitable dry location.

The machine must be located in an area properly protected from the weather.

3. Shut off gas and electricity before starting installation or service. Turn back on to test or operate.
4. **DO NOT** connect appliances before pressure testing the gas piping. Damage to gas valve may result. (6 - 14 w.c.i. or 1/2 psig)
5. **DO NOT** insert any object other than suitable pipe or tubing in the inlet or outlet of the gas valve. Internal damage may occur and result in a hazardous condition.
6. **DO NOT** grip gas valve body with a pipe wrench or vise. Damage may result causing gas leakage. Use inlet or outlet bosses or a special body wrench.
7. **DO NOT** short the gas valve terminals.
8. **DO NOT** allow any flame to impinge on the regulator vent tubing if supplied. It may clog and cause gas valve malfunction.
9. **DO NOT** use the gas cock to adjust gas flow.
10. If main burner fails to shut off, turn off gas supply.
11. Keep all combustible materials away from gas appliances. **DO NOT** allow lint or dust to collect in burner area.
12. Dials must only be operated by hand. Never use pliers, wrenches or other tools to turn dials.
13. After installation or servicing, test for leaks with a soap solution. With the main burner on, coat pipe and tubing joints, gaskets, etc. Bubbles indicate leaks.
14. If the machine is installed in an enclosed room, care should be taken to ensure that an adequate supply of air is available for combustion and ventilation. (1 sq. inch per 1000 BTU)

Operations

Checklist Prior To Operation

	YES	NO
Has gas supply been inspected by an authorized contractor to meet local codes?		
Is machine protected from downdraft and excessive wind?		
Is machine shielded from moisture or water spray?		
Is the voltage correct and are the circuit breaker and supply cord adequate according to specifications and serial plate notation?		
Is the machine electrically grounded?		
Is there ample water supply?		
Have all flammable liquids or gases been removed from installation location?		
Is there adequate gas supply for the BTU rating of the burner?		
Is incoming gas supply pressure between 6 - 14 water column inches or 1/2 PSIG?		
Has the proper gas regulator been installed for pressure and volume?		
Is the machine properly vented to allow adequate air flow?		
Are propane tanks large enough, according to rating to prevent freezing?		
Have gas lines been checked for gas leaks?		
Have gas lines been checked with local codes?		
Have all operators using this machine been instructed properly & have they read the manual?		
Has machine been installed according to operator's manual instructions?		

DANGER: If "NO" has been checked on any of the above questions, do not operate the machine.



DANGER: Si la réponse à l'une des questions ci-dessus est « NON », ne pas utiliser la machine.

DANGER: This machine is equipped with an electronic ignition system. Lighting of the pilot is accomplished through

electronic spark ignition. Do not attempt to light the appliance manually as a burn injury or electrical shock may result.

DANGER: Cette machine est équipée d'un système d'allumage électronique. L'allumage de la veilleuse est effectué par le biais d'un allumage électronique. Ne pas tenter d'allumer l'appareil manuellement, car cela risquerait de causer des brûlures ou des chocs électriques.

FOR YOUR SAFETY READ BEFORE LIGHTING

WARNING

If you do not follow these instructions exactly, a fire or explosion may result causing property damage, personal injury or loss of life.

A. This appliance has an electronic ignition system. When lighting the pilot, follow these instructions exactly.

B. BEFORE LIGHTING smell all around the appliance area for gas. Be sure to smell next to the floor because some gas is heavier than air and will settle on the floor.

FOR YOUR SAFETY

"WHAT TO DO IF YOU SMELL GAS"

- Do not try to light any appliance.
- Do not touch any electrical switch, do not use any phone in your building.
- Immediately call your gas supplier from a neighbor's phone. Follow the gas supplier's instructions.
- If you cannot reach your gas supplier, call the fire department.

C. Use only your hand to turn the gas control. Never use tools. If the knob will not push in or turn by hand, don't try to repair it; call a qualified service technician. Forced or attempted repair may result in a fire or explosion.

D. Do not use this appliance if any part has been under water. Immediately call a qualified service technician to inspect the appliance and to replace any part of the control system and any gas control which has been under water.

Operation Instructions

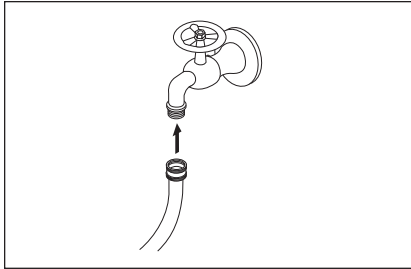

STEP 1: Review installation instructions prior to connecting water supply.

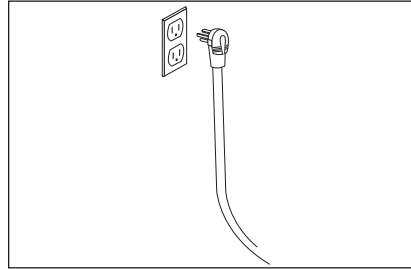

STEP 2: Connect accompanying pressure washer and burner module to appropriate power supply.

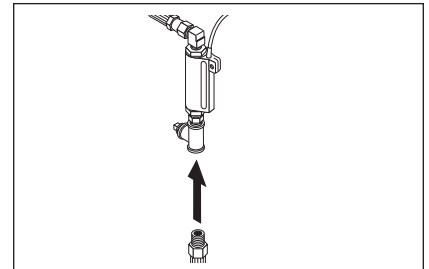

STEP 3: Connect high pressure hose from attached pressure washer (not included) to burner module.

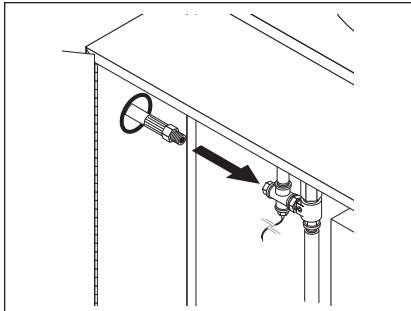

STEP 4: Connect high pressure hose to burner module outlet.

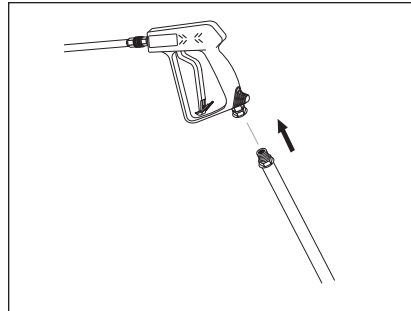

STEP 5: Assemble spray gun to high pressure outlet hose. Attach desired nozzle to end of wand and secure it in place.

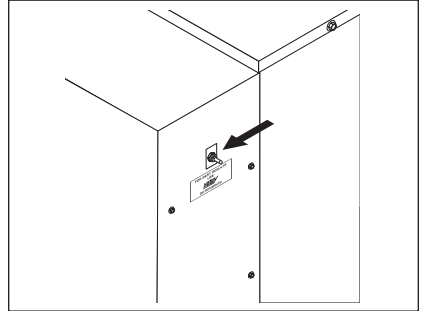

STEP 6: Turn on burner switch. Pilot ignition will begin to spark. Confirm pilot light ignition, if unsuccessful, turn of switch and turn on again. If pilot continues to spark, but not light, consult troubleshooting guide.

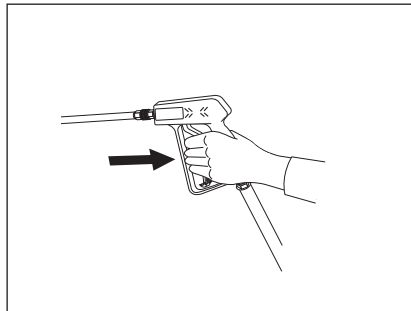

STEP 7: Start attached pressure washer according to manufacturer's safety and operation instructions then pull trigger on spray gun to allow water flow.

Operations

Detergents And General Cleaning Techniques

Pre-rinse cleaning surface with fresh water. Place detergent suction tube directly into cleaning solution and apply to surface at low pressure (for best results, limit your work area to sections approximately 6 feet square and always apply detergent from bottom to top). Allow detergent to remain on surface 1-3 minutes. Do not allow detergent to dry on surface. If surface appears to be drying, simply wet down surface with fresh water. If needed, use brush to remove stubborn dirt. Rinse at high pressure from top to bottom in an even sweeping motion keeping the spray nozzle approximately 1 foot from cleaning surface. Use overlapping strokes as you clean and rinse any surface. For best surface cleaning action spray at a slight angle.

Recommendations

- Before cleaning any surface, an inconspicuous area should be cleaned to test spray pattern and distance for maximum cleaning results.
- If painted surfaces are peeling or chipping, use extreme caution as pressure washer may remove the loose paint from the surface.
- Keep the spray nozzle a safe distance from the surface you plan to clean. High pressure wash a small area, then check the surface for damage. If no damage is found, continue to pressure washing.

CAUTION - Never use:

- Bleach, chlorine products and other corrosive chemicals
- Liquids containing solvents (i.e., paint thinners, gasoline, oils)
- Tri-sodium phosphate products
- Ammonia or Acid-based products

These chemicals will harm the machine and will damage the surface being cleaned.

ATTENTION - Ne jamais utiliser :

- Eau de Javel, produits à base de chlore et autres produits chimiques corrosifs
- Liquides contenant des solvants (c.-à-d. diluant à peinture, essence, huiles, etc.)
- Produits à base de tripolyphosphate de sodium
- Ammoniac ou produits à base d'acide

Ces produits chimiques endommageront la machine et endommageront la surface étant nettoyée.

Rinsing

It will take a few seconds for the detergent to clear. Apply safety latch to spray gun. Select and install desired high pressure nozzle.

NOTE: You can also stop detergent from flowing by removing detergent siphon tube from bottle.

Shutting Down And Clean-Up

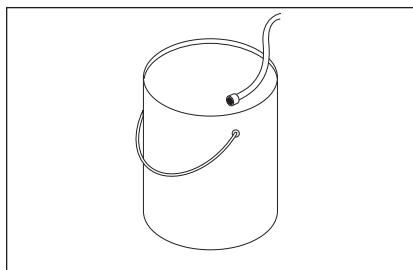

STEP 1: To clean detergent from hose and wand, insert end of detergent hose in clean bucket of water and run for a few minutes until steady stream of clean water is evident.

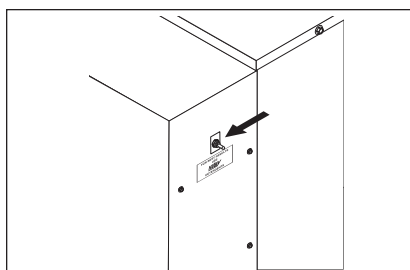

STEP 2: Turn burner switch off and continue spraying, allowing the water to cool to below 100°F.

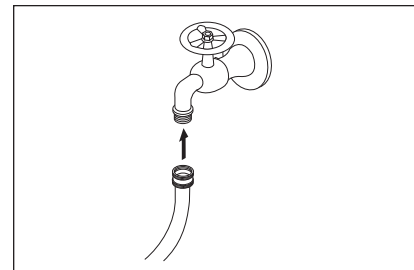

STEP 3: Turn water off.

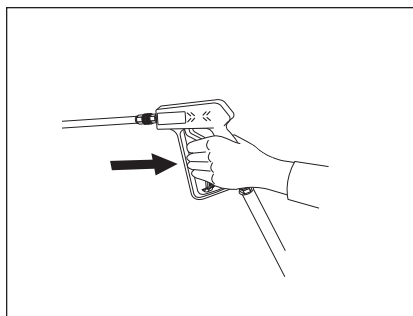

STEP 4: Open spray gun to relieve remaining pressure.

Operations

Basic Facts

Based on 60°F	Propane	Butane
Formula	C3H8	C4H10
Vaporization Point (oF)	-43.7	31.1
Specific Gravity (Vapor)	1.522	2.006
Specific Gravity (Liquid)	0.508	0.584
Lbs. Per Gallon (Liquid)	4.23	4.87
B.T.U. Per Cubic Foot (Vapor)	2.563	3.39
B.T.U. Per Lb. (Vapor)	21.663	21/3-9
B.T.U. Per Gallon (Liquid)	91.74	1-3/93
Cubic Feet Per Lb. (Liquid)	8.607	7/53
Cubic Feet Per Gallon (Liquid)	3.45	31/9
Octane Number	125	1
Molecular Weight	44.09	58.12
To calculate running cost:		
1 cubic Ft./1,000 B.T.U.		
100 cubic Ft./Therm		
Therm/Hour		
50¢ Therm		
Example:	Using natural gas	
	400,000 BTU Machine	
	400 cubic feet	
	4 Therms/hour	
	4 x .50 = \$2.00/hour to run	

Pressure Equivalents

Simply stated, pressure is the force exerted by a gas or liquid attempting to escape from a container. It is useful to know how strong this “attempt to escape” is. Pressure can be measured with a manometer or with a pressure gauge. At the lower levels, it is expressed in “water column inches” i.e. 1 w.c.i. Higher pressures are expressed in terms of the force exerted against a square inch of area. For example, 125 lbs. per square inch (125 psi).

1 Water Column Inch	=	50 Oz./Sq. In.	11 Water Column Inches	=	6.35 Oz./Sq. In.
11 Water Column Inches	=	4 Lb./Sq. In.	1 Lb./Sq. In.	=	27.71 Water Column Inches
1 Lb./Sq. In.	=	2.04" Mercury	1" Mercury	=	.39 Lb./Sq. In.
1 Std. Atmosphere	=	14.73 Lbs./Sq. In		=	-

Maintenance

Preventative Maintenance

1. Follow Winterizing Procedures to prevent freeze damage to the pump and coils.
2. Always neutralize and flush detergent from system after use.
3. If water is known to be high in mineral content, use a water softener in your water system or de-scale as needed.
4. Do not allow acidic, caustic or abrasive fluids to be pumped through system.
5. Always use high grade quality cleaning products.
6. Always cool the heating module.
7. Periodically delime coils per instructions.

It is advisable, periodically, to visually inspect the burner. Check air inlet to make sure it is not clogged or blocked. Wipe off any oil spills and keep this equipment **clean and dry**.

The areas around this heating module should be kept clean and free of combustible materials, gasoline and other flammable vapors and liquids.

The flow of combustion and ventilating air to the burner must not be blocked or obstructed in any manner.

Maintenance And Service

Winterizing Procedure

Damage due to freezing is not covered by warranty. Follow these cold weather procedures whenever the washer must be stored or operated outdoors under freezing conditions.

If the water heater will be exposed to freezing weather, an anti-freeze solution should be circulated through the coils by whatever means are available for the particular system the water heater is used on. If compressed air is available, an air fitting can be screwed into the discharge coupling fitting and by injecting compressed air, all water will be blown out of the system. The use of a draft diverter will prevent the wind chill factor from freezing the coil.

Heating Coils

To Check Water Heater Coil for Leaks

With the main burners "OFF" start the attached pressure washer and allow it to run for a few minutes. Check into the burner compartment with a drop light or flashlight. If no leaks are visible, then water dripping from coil is from condensation in the flue gases when the burner is on.

Condensation from Heating Coil

When cold water is being pumped into the water heater coils, and the burner is on, condensation will form on the coil and drip down into the burner compartment, giving the appearance of a leaking coil, particularly on cold humid days.

Deliming Coils

In alkaline water areas, lime deposits can accumulate rapidly inside the coil pipes. This growth is increased by the extreme heat build up in the coil. The best prevention for liming conditions is to use high quality cleaning detergents. In areas where alkaline water is an extreme problem, periodic use of Deliming Powder will remove lime and other deposits before coil becomes plugged.

Periodic flushing of coils is recommended.

1. Fill a container with 4 gallons of water, then add 1 lb. of deliming powder. Mix thoroughly and check label for proper solution mixing ratio.
2. Remove nozzle from spray gun assembly and put spray gun into container. Secure the trigger on the spray gun into the open position.
3. Attach a short section (3-5 ft.) of garden hose to machine to siphon solution from an elevated container, or add mixture to the float tank. Turn pump switch on allowing solution to be pumped through coils and back into the container. Solution should be allowed to circulate 2-4 hours.
4. After circulating solution, flush entire system with fresh water. Reinstall nozzle in spray gun.

Gas Valve Regulator Adjustment

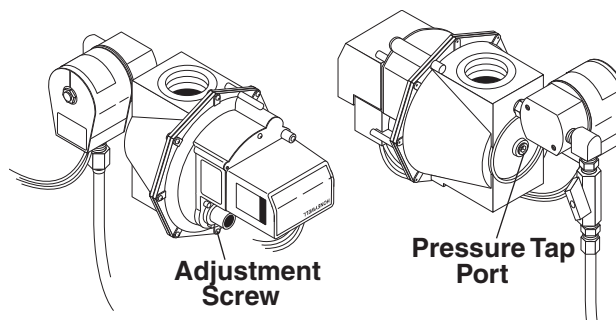

Adjustment of the built-in regulator isn't normally necessary, since it is preset at the factory. However, field adjustment may be accomplished as follows:

1. Attach manometer at pressure tap port.
2. Remove regulator adjustment screw cap.
3. With small screwdriver, rotate adjustment screw clockwise to increase or counterclockwise to decrease gas pressure.

Pressure Relief Valve

Each machine is equipped with a relief valve to relieve pressure in the system when higher than normal operating pressures are encountered or if the unloader valve should fail. Unusually high pressures come from an object plugging the spray nozzle. If operating pressure is found to be normal and the relief valve continues to leak, repair or replace valve. The Safety Relief Valve should be opened to release any sediment yearly. Start the pressure washer and use an Allen wrench to turn the pressure relief valve counter clockwise until water is pouring out the valve. Then turn the adjustment nut/bolt until the valve stops leaking. Open and close the trigger gun and if water squirts out the valve when you close the trigger gun turn clockwise one full turn until there is no leaking when the trigger gun is closed.

Propane Gas (Optional Conversion Kit)

General Safety Precautions

Have a qualified gas service person assist in any gas burner installation or service. Few maintenance people or mechanics are knowledgeable in gas controls or related safety practices. Propane gas is heavier than air, unburned propane gas will gravitate to the floor rather than rise out of the stack. Hence, adequate floor space and good ventilation are especially important with propane systems.

Gas Pressure Requirements

All propane fired machines operate on gas phase only. They are designed to operate at a pressure of 11 water column inches (between 1/3 and 1/2 of one PSI), and are often operated at even higher pressures when extra heat is needed.

Exterior regulators are needed to control the system. Propane bottles are not included with machine. A high pressure regulator should be installed on propane bottle and a low pressure regulator attached to the pressure washer.

Propane Cylinder Capacity

An important consideration with propane systems is the capacity of the supply cylinder relative to the needs of the burner. The burner operates on propane as a gas. As gas is used from the propane cylinder, the liquid in the cylinder boils to maintain gas pressure. This boiling process cools the liquid, and in a heavy, continuous-demand situation, the liquid temperature can fall to the point at which it cannot provide gas as rapidly as is needed. In this case, it may be necessary to warm the PROPANE CYLINDER by directing a warm spray, not over 120°, on the cold cylinder, or by manifolding two propane bottles together to increase total vaporization

capacity. It is recommended that a minimum 100 lb. propane bottle be used on the machine, depending on the length of running time desired.

Burner Features

Operated Automatic Valve

This machine is equipped with an Intermittent Pilot Ignition System. This system is designed to eliminate the need for a constant burning pilot. Lighting of the pilot is accomplished through electronic spark ignition each time the burner and flow switch call for heat. The pilot is not burning when there is no call for heat. Do not attempt to light the appliance manually as a burn injury or electrical shock may result. The pilot light will remain on and the main gas valve is turned off when the spray gun is closed.

Care of Main Burner

Due to condensation from heater coils dripping down on the burners, scale build-up may occur in the burner jet orifices.

1. TO REMOVE BURNER MANIFOLD FROM WATER HEATER COIL:

Turn off the gas at the main burner by turning the knob to the "OFF" position on the gas valve and main gas supply.

Disconnect the pilot and ignition lines from the gas valve. Disconnect union in main burner line. Slide burner manifold out through shell opening.

2. TO CLEAN BURNER JETS:

Select proper size drill for type of gas involved. Use pine vise to hold drill, then ream out each jet orifice.

CAUTION: Do not ream out orifices to a larger size.

ATTENTION: Ne pas agrandir les orifices.

Preventative Maintenance

This pressure washer was produced with the best available materials and quality craftsmanship. However, you as the owner have certain responsibilities for the correct care of the equipment. Attention to regular preventative maintenance procedures will assist in preserving the performance of your equipment. Contact your dealer for maintenance. Regular preventative maintenance will add many hours to the life of your pressure washer. Perform maintenance more often under severe conditions.

MAINTENANCE SCHEDULE	
Remove Burner Soot From Heating Coil	Annually
Descale Coil	Annually - (more often if required)
Replace Quick Connects	Annually
Clean Water and Detergent Screen/Filter	Weekly
Clean Float/Supply Tank	Every 6 months
Replace HP Hose	If there is any sign of wear
Grease Motor	Every 10,000 hours
Check Burner Pilot Jets	Annually
Pressure Relief Valve	Open annually to remove any sediment

Oil Change Record

Date Oil Changed Month/Day/Year	Estimated Operating Hours Since Last Oil Change

Date Oil Changed Month/Day/Year	Estimated Operating Hours Since Last Oil Change

Maintenance

Troubleshooting

PROBLEM	POSSIBLE CAUSE	SOLUTION
FLOW & BURNER SWITCH ON; NO SPARK, NO PILOT GAS	A. No main power	With power switch on, open trigger on spray gun and set your test meter to the 24 volt scale. Probe terminals 24V and 24V(GND). If you do not read 24 volts, the problem is not the ignition system. Perform normal system checks of main power, transformer, thermostat and the limit control. If you do read 24 volts at TH and GND, the problem is in the ignition system. Check for loose or defective wiring. If wiring is good, replace the ignition control unit.
	B. Faulty transformer	
	C. Faulty burner & flow switch	
	D. Faulty ignition control unit	
HAVE SPARK, NO PILOT GAS FLOW	Main gas supply turned off	Set test meter to 24 volt scale.
		1. Be sure main gas valve (gas cock or selector arm) is turned on.
		2. With gas on and system sparking, probe terminals PV and 24V(GND). If pilot gas does not flow with 24 volts at these terminals, replace gas valve.
		3. Probe terminals PV and MV/PV. If 24 volts not present, replace ignition control box.
HAVE PILOT GAS, NO SPARK	A. Defective ignitor/sensor and or its wiring	Set test meter to ohm scale.
		1. Disconnect the wire from the IGN terminal on the ignition control unit.
	B. Faulty ignition control unit	2. Touch one meter probe to the tip of the ignitor/sensor rod in the pilot. Touch the other probe to the quick connect at the other end of ignitor/sensor wire.
		3. If you have continuity from the tip of the ignitor/sensor rod to the connector and no spark, replace the ignition control unit.
		4. If you do not have continuity through wire and the ignitor/sensor, check for a loose wire connection in the wire. Repair as needed.
		5. Check to see if spark shorts to burner ring through a cut in the ignitor wire.

PROBLEM	POSSIBLE CAUSE	SOLUTION
<p>HAVE PILOT FLAME, MAIN BURNER WILL NOT TURN ON</p>	<p>Faulty main valve coil in the gas valve</p>	<p>Set test meter to 24 volt scale</p>
	<p>Faulty ignitor/sensor and/or its wiring</p>	<p>With pilot flame on ignitor/sensor, probe terminals MV and MV/PV on the ignition control unit. If you read 24 volts here but not at the gas valve, there is a loose wiring connection. Repair or replace as needed.</p>
	<p>Ground wire not attached to machine chassis</p>	<p>If you do read 24 volts at MV and MV/PV and the pilot flame is impinging on the ignitor/sensor rod, the problem may be:</p> <ul style="list-style-type: none"> a. Faulty ignitor/sensor and/or its wiring. b. Faulty ignition control unit.
		<p>Set test meter to the ohm scale. Turn burner switch off.</p>
		<p>Check continuity through the green ground wire and its connections.</p>
		<p>Reconnect the ignitor/sensor wire and the ground wire.</p>
		<p>Turn burner switch on. With the pilot burning and the flame on the ignitor/sensor rod, the main burner should turn on. If it does not, replace the ignition control unit.</p>
<p>SHORT-CYCLING OF MAIN BURNER. MAIN BURNER TURNS OFF BEFORE THE BURNER SWITCH OR FLOW SWITCH IS TURNED OFF.</p>	<p>Draft condition pulls flame away from ignitor/sensor rod</p>	<p>Check the thermostat by bypassing at terminals P1 and 1.</p>
		<p>Set thermostat high. With main burner on, observe the pilot flame impingement on the ignitor/sensor.</p>
	<p>Faulty thermostat or water temperature is too high</p>	<p>If pilot is small and draft condition pulls flame from ignitor sensor rod, the burner will turn off and then on again.</p> <ul style="list-style-type: none"> a. Adjust pilot flame higher or clean pilot orifice. b. Bend ignitor/sensor rod closer to pilot flame.
		<p>If flame impingement on the ignitor/sensor is stable and the system short-cycles, check the limit switch.</p>
		<p>Set test meter to 110 volt scale.</p> <ul style="list-style-type: none"> a. When the system cycles off, probe the switch terminals of the limit switch. b. If you read 24V across the switch terminals the limit switch is open. Replace the limit switch.
		<p>A pilot flame set too high will also cause burner to short cycle. Pilot flame lifts over ignitor/sensor.</p>

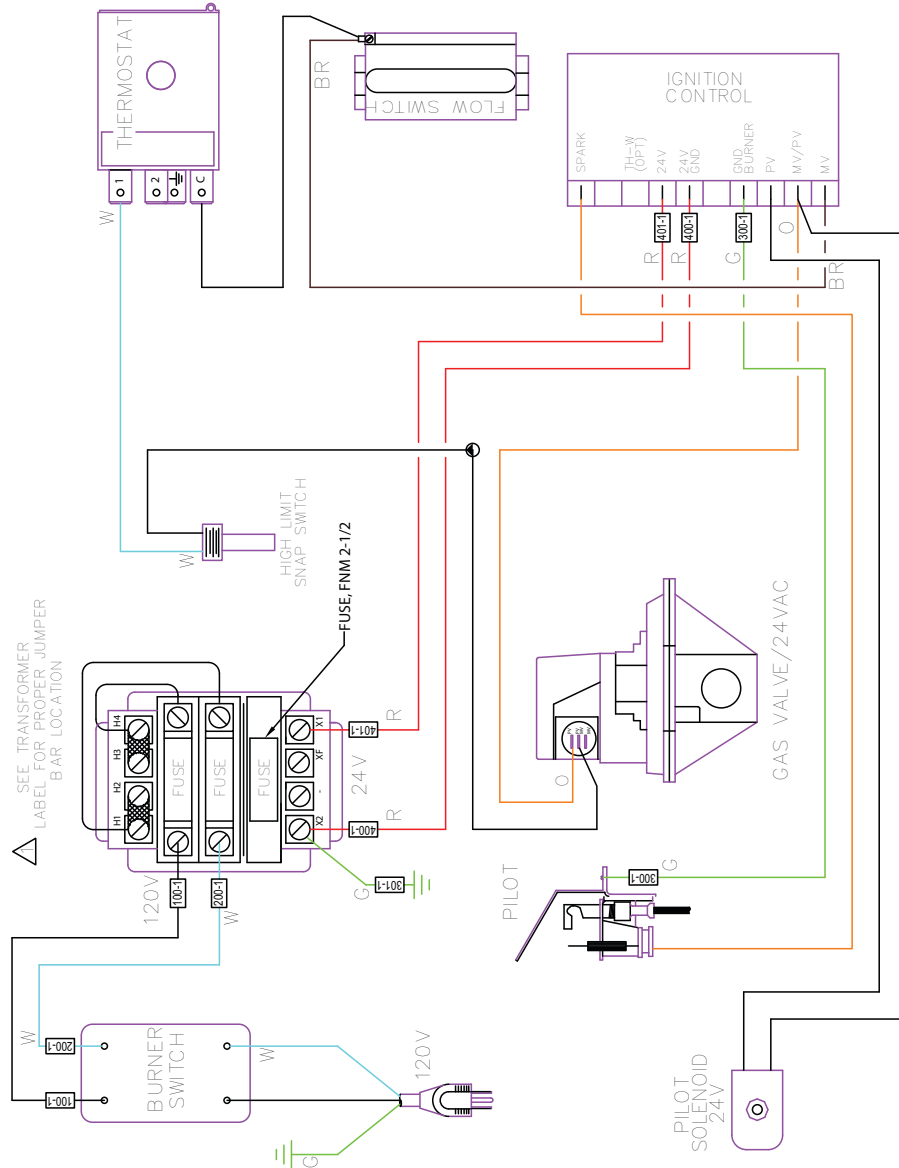

NOTE:

1. READ TRANSFORMER FOR JUMPER LOCATION.
2. CAUTION - PLEASE NOTE COMPONENT VOLTAGE REQUIREMENTS

WIRE COLOR LEGEND	
ALL WIRES BLACK UNLESS NOTED	
B / 1**	BLACK
W / 2**	WHITE
G / 3**	GREEN
R / 4**	RED
BL / 5**	BLUE
GR / 6**	GRAY
Y / 7**	YELLOW
O / 8**	ORANGE
V / 9**	VIOLET

