

BEFORE
CONTROL UNIT INSTALLATION

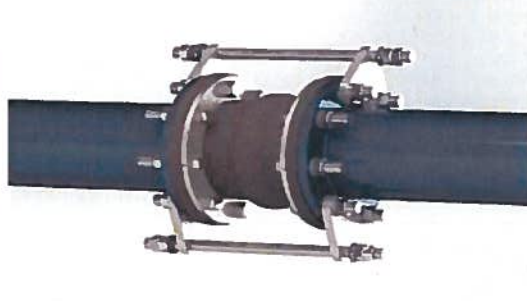

AFTER
CONTROL UNIT INSTALLATION

Pipe Diameter	No. of Control Rods Needed for Maximum Pressure Listed				
	2	3	4	6	8
1/2	1328	-	-	-	-
3/4	1106	-	-	-	-
1	949	-	-	-	-
1 1/4	830	-	-	-	-
1 1/2	510	-	-	-	-
2	661	-	-	-	-
2 1/2	529	-	-	-	-
3	441	-	-	-	-
3 1/2	365	547	729	-	-
4	311	467	622	-	-
5	235	353	470	-	-
6	186	278	371	-	-
8	163	244	326	-	-
10	163	244	325	488	-
12	160	240	320	481	-
14	112	167	223	335	-
16	113	170	227	340	453
18	94	141	187	281	375
20	79	118	158	236	315
22	85	128	171	256	342
24	74	110	147	221	294
26	62	93	124	186	248
28	65	98	130	195	261
30	70	105	141	211	281
32	63	94	125	188	251
34	72	107	143	215	286
36	69	103	138	207	276
38	63	94	125	188	251
40	42	63	85	127	169
42	48	72	96	144	192
44	44	66	88	133	177
46	41	61	82	122	163
48	40	60	81	121	161
50	37	56	75	112	150
52	35	53	70	105	140
54	43	64	86	128	171
56	40	60	80	120	160
58	38	56	75	113	150
60	35	53	71	108	141
62	33	50	66	100	133
66	30	44	59	89	119
72	25	38	50	75	101
78	28	42	56	84	112
84	24	37	49	73	98
90	26	40	53	79	106
96	29	43	58	86	115
102	25	33	51	76	102
108	23	34	46	75	92
120	18	28	37	56	75
132	15	23	31	46	62
144	13	19	26	39	52

* From Fluid Sealing Association Technical Handbook for Non-Metallic Expansion Joints.